

Computer Networks I

Origins

- US Department of *Defense* Advanced Research Projects Agency
 - Budget insufficient to provide computers for all scientists and engineers
 - 1960's: share specialized computers between groups
 - Challenges: How are computers to communicate? Want to achieve efficiency, not lose data.

2

Today

- Why use a computer network?
 - Sharing of hardware resources (printers, scanner, etc.)
 - Sharing of software resources (programs, files)
 - Human-to-human communication (instant messaging, email)
 - Distribute large complex tasks on several machines simultaneously (SETI*Search for Extraterrestrial Intelligence*@home)
 - Play multi-player games

3

Message Transmission

- Transmission is a term used to represent the actual relaying of a message between a sender computer and a receiver computer
- Two main types of transmission media:
 - Wired transmission media
 - Twisted-pair cable
 - Coaxial (Cable TV) cable
 - Fiber-optic cable
 - Wireless transmission media
 - Radiowaves
 - Infrared waves



4

Communication Protocols

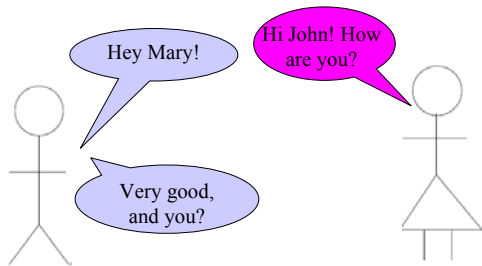

5

Communication Protocols

- Why was this communication successful?
 - Both people can hear and speak
 - Both people are speaking same language
 - Refers to the other by name
 - Shows willingness to communicate
 - Established a 'polite' communication pattern
 - Used special greeting words (eg. 'hey', 'hi')

6

Communication Protocols

- **Humans** abide by **rules** when they communicate:
 - We use the same frequency range
 - Languages are structured
 - Pattern: greet, talk, then listen, ...
- **Computers** must abide by strict **rules** to avoid communication problems

7

Communication Protocols

- A **protocol** is a set of rules that governs how computers have a “conversation”
- Eg. Protocol:
 - If a computer sends another computer a single bit set to '1', it is trying to reach that computer (ie. to see if it is awake/functional)
 - If a computer receives a single bit set to '1' from another computer, it sends it back a '0'-bit to indicate that it is awake/functional

8

Layered Communication

- Layers break the communication process into manageable **chunks**
- Each layer is **independent** of the other layers
 - changes made to protocols that effect one layer will not affect the other layers
- Each layer receives a message from the **upper** layer, and calls upon the services of the **lower** layer
- Effectively, **layer x** on one machine communicates with **layer x** on another machine.
- Each layer has **protocols** associated with the layer for specific purposes

9

Locating Computers on the Network – IP Address

- Suppose we have a simple network:
 - Each computer must have some **unique id**
 - Each computer could be identified by a unique IP address
 - Could be thought of as a **street address**
- Example: 192.168.10.123

10

Sending Information

- Suppose we have computers A and B
- Computer A wants to send a message to computer B
- All computer A knows is B's IP address
- A "signs" all messages it sends with B's IP address
- All computers on the network get the messages, but only B reads them



11

Internet Protocol (IP)

- **IP packet** consists of an **IP header** and **IP data**
- **IP header** contains information such as source IP address, destination IP address, size of the IP data
- **IP data** contains any kind of data you want to transfer between two computers



12

Internet Protocol

Unreliable:

- data corruption
- duplicate arrival
- out of order (packet A may be sent before packet B, but B can arrive before A)
- lost or “dropped/discarded” packets
- Not very useful by itself

13

Transmission Control Protocol (TCP)

- For many forms of communication need reliability
- Need to know when communication has **started and ended**
- If a message is broken into multiple parts, once you get all the parts need to know how to **put them back in order**
- TCP solves all these problems

14

Transmission Control Protocol (TCP)

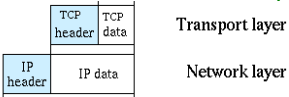
- TCP is a protocol constructed **on top of IP**
- 
- | | | |
|------------|----------|-----------------|
| TCP header | TCP data | Transport layer |
| IP header | IP data | Network layer |
- Each TCP packet consists of **TCP header** and **TCP data**, similar to IP
 - TCP header contains the source port, destination port, sequence number and acknowledgement (ACK) number

15

TCP ports

- If **IP address** is like a **building number**; **port** is like an **apartment number**
- If one wants to send data to a certain program running on a computer, the program needs to be **listening** for the data
- Information needs to be sent not only to the right computer (IP address) but to the right port on this computer

16

Three-Way Handshake

- Before communication can be started both ends must ensure that they have a **stable connection** and are **ready to send and receive data** : three-way handshake is a way of doing that
- Sent in the **acknowledgement portion** of the TCP header
 1. Initiator: SYN
 2. Receiver: SYN-ACK
 3. Initiator: ACK
- Once all three are sent and received, communication is established

17

Sequence Numbers

- Recall that IP provides **no guaranties on the order of packet delivery** and TCP packets are stored in the IP packets
- Also part of the TCP header
- Used to reconstruct the complete message and to **detect if any portions were not delivered**
- Used to indicate to sender if something was not received and needs to be retransmitted

18

Example

19

HTTP

- Can TCP be further subdivided?
- Sure! TCP data portion can contain other packets, for example an HTTP packet

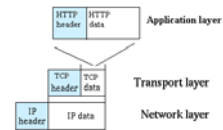

20

Is TCP good for everything

- TCP provides complete reliability, this is not always necessary, for example Voice over IP, if one sound out of a conversation is lost it will not affect understanding
- TCP communication has a **big overhead**, TCP header is relatively large and the receiving client is required to respond
- Need a lighter protocol

21

User Datagram Protocol (UDP)

- On the same level as TCP
- Of all the “interesting” information in the TCP header, UDP contains only the **port number**
- Is not reliable but very light and sufficient for certain types of applications
- Commonly used for streaming media (real time), online games, etc.

22

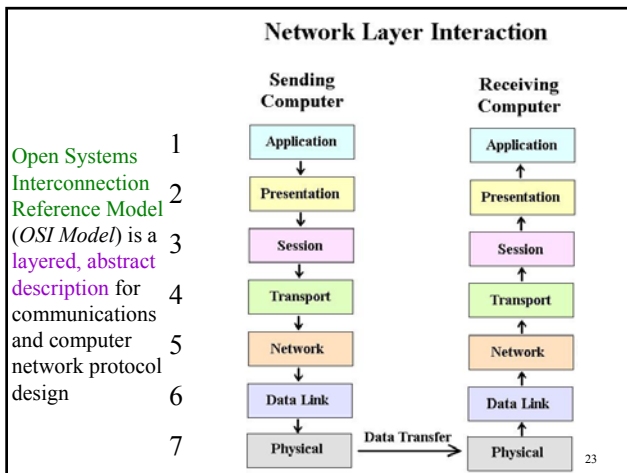

Data Transfer

- For a transfer from host x to host y :
 - The **size of the transfer** is the total number of **bits** b transferred
 - The **total time of the transfer** is the total amount of **time** it took for the transfer

24

Network Performance

- The *latency* is the amount of time it takes a single bit of information to get from x to y .
- The *bandwidth* (bps) is the amount of information that can be sent per second
- The *optimal bandwidth* (b_{opt}) is the maximum bandwidth a link could ever achieve.
 - Videotron's high-speed optimal download bandwidth is 7 Mbps
 - Videotron's extreme plus high-speed optimal download bandwidth is 20 Mbps (as of 25/09/06)
- The *network efficiency* is the fraction b/b_{opt}

25

Data Transfer

- The latency is usually seen as the length of a pipe, while the bandwidth is seen as the width of the pipe.



26

Kinds of Networks: Geographically

- PAN (Personal Area Network)
- LAN (Local Area Network)
- MAN (Metropolitan Area Network)
- WAN (Wide Area Network)

27

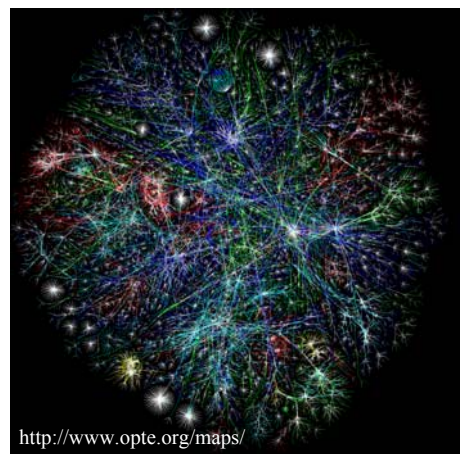

<http://www.opte.org/maps/>

28